



# STERO SU

## HOT AND COLD UNDERCOUNTER



### STANDARD FEATURES

- Drain water tempering kit
- 31 racks per hour rate – SUH
- 33 racks per hour rate – SUL
- .78 gallons of water per rack
- Hot water or chemical sanitizing units available
- Low chemical alert indicators
- Booster heater capable of 70° rise, provided on SUH models
- Rinse Assurance ensures 180° final rinse
- Self-priming chemical pumps
- Error notification
- Digital cycle/temperature display
- Interchangeable upper and lower wash and rinse arms
- Pumped drain
- Pumped rinse
- 17" door opening
- Automatic tank fill
- Chemical pumps standard



### OPTIONS & ACCESSORIES

- Power cord kits
- 6" base
- 17" stand

MACHINE RATINGS	SUH Hot Water Sanitizing	SUL Chemical Sanitizing
Racks per Hour Rate	31	33
Cycle Time – Seconds	116	109
Tank Heat	1.8 KW	1.8 KW
Electric Booster Heater	4.9 KW	N/A
Water Usage Per Rack – Gallons	.78	.89
Peak Drain Flow – Gallons per Minute	4.0	4.0
Incoming Water Temperature Required (minimum)	110°	120°

# STERO SU

## HOT AND COLD UNDERCOUNTER



### NOTICE

Required flowing water pressure to the dishmachine is 15-65 PSIG. If pressures higher than 65 PSIG are present, a pressure regulating valve must be installed in the water line to the dishmachine (by others).

Pressure gauge not required on pumped rinse machines.

Important: Chemical containers should be placed no higher than 10" above floor.

If chemical containers are to be placed in cabinet adjacent to machine, a 1/2" dia. hole is required in the cabinet to run chemical supply line.

Use only 6% or 8.4% sodium hypochlorite (liquid bleach) as sanitizing chemical to insure proper operation of dishmachine (SUL only).

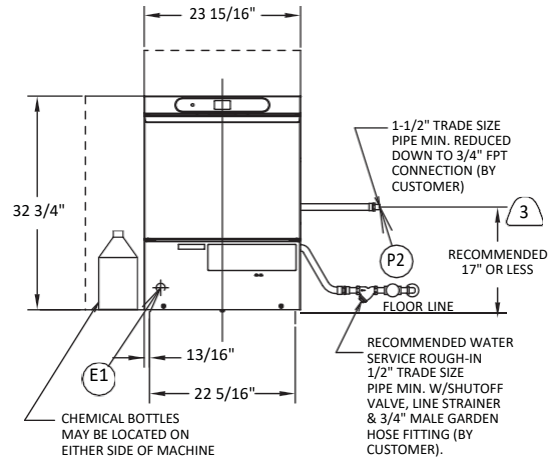
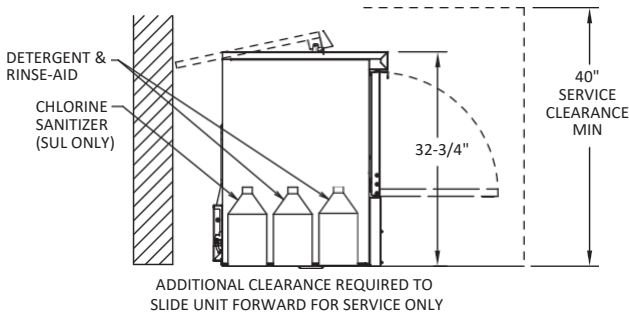
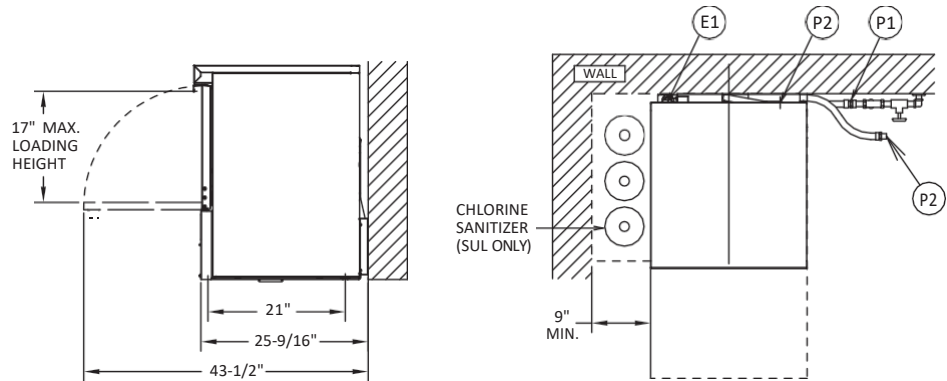

### NOTES:

- All vertical machine dimensions taken from floor may be increased by 1".
- Moist air escapes from the door. Use only moisture resistant materials adjacent to dishmachine sides and top.
- A vent hood is not recommended above the undercounter dishmachine since it does not produce excessive vapors.

### PLUMBING NOTES:

- Water hammer arrestor (meeting ASSE-1010 Standard or equivalent) to be supplied (by others) in common water supply line at service connection.
- Recommended water hardness to be 3 grains or less for best results.
- If drain hose is looped above a sink, the loop must not exceed 38" AFF.

### WARNING

Electrical and grounding connections must comply with the applicable portions of the National Electrical Code and/or other local electrical codes.

Plumbing connections must comply with applicable sanitary, safety and plumbing codes. Drain and fill line configurations vary, some methods are shown on this drawing.

MODEL	VOLTS/HERTZ/PHASE	RATED AMPS	MIN SUPPLY CKT CONDUCTOR AMPACITY	MAX PROTECTIVE DEVICE
SUH	120/208-240(3W)/60/1*	30.5	40	40
SUL	120/60/1	15.4	20	20

NOTE: FOR SUPPLY CONNECTIONS, USE COPPER WIRE ONLY RATED AT 90°C MINIMUM ACCESSORY CORD KIT AVAILABLE FOR ALL MODELS.

\* THIS SYSTEM REQUIRES THREE POWER WIRES WHICH INCLUDES A CURRENT CARRYING NEUTRAL, AN ADDITIONAL FOURTH WIRE MUST BE PROVIDED FOR A MACHINE GROUND.

**NOTE:** Certain materials, including silver, aluminum and pewter are attacked by sodium hypochlorite (liquid bleach) in the chemical sanitizing dishwasher mode of operation. Water hardness must be controlled to 3 grains OR LESS for best results.

### CONNECTION INFORMATION

(AFF = ABOVE FINISHED FLOOR)

### LEGEND

- E1 ELECTRICAL CONNECTION: 1-3/8" DIA. HOLE FOR 1" TRADE SIZE CONDUIT; 4-5/8" AFF
- P1 SINGLE FILL AND RINSE CONNECTION: 3/4" FEMALE GARDEN HOSE FITTING ON 6' LONG HOSE SUPPLIED WITH MACHINE;
- P2 DRAIN CONNECTION: 5/8" BARB FITTING WITH 6' LONG HOSE SUPPLIED WITH MACHINE.

### WARNING

Do not premix other chemicals and sodium hypochlorite (liquid bleach). Mixing may cause hazardous gas to form (SUL only).

SHIPPING WEIGHTS		
MODEL	NET WEIGHT	DOMESTIC SHIPPING WEIGHT
SUH	150 lbs.	170 lbs.
SUL	150 lbs.	170 lbs.

**OVERALL DIMENSIONS:** 32-3/4"H x 23-15/16"W x 25-9/16"D

In line with its policy to continually improve its products, Stero reserves the right to change materials and specifications without notice.